



ROLLER BALL

Multi-Function Hair Processor







The Icon of the Future

The slim, elegant form signifies a new future in the salon.
ROLLER BALL F—bringing new possibilities in hair design.



More Sophisticated, More Stylish

ROLLER BALL F

An Innovative Product Created by Takara Belmont

A far-infrared hair processor is essential for effectively processing colour, perms, and other treatments. The world's first far-infrared dome with a rotating ring was implemented in the ROLLER BALL, a leading Takara Belmont product. With an open feeling and chic-yet-functional style that you don't find in hood-based processors, it remains popular in Japan—and the rest of the world—more than 20 years after its first release.

ROLLER BALL F is Revolutionising the Future of the Salon

And now, a new generation of ROLLER BALLs has been conceived: ROLLER BALL F ('F' for 'Future'). Complementing its stylish and futuristic design are several advancements in performance—for example, an industry-first* carbon element—that make the ROLLER BALL F a powerful tool that will revolutionise the future of hair design. Evoking an image of high-end therapeutic technology and sporting a beautiful finish, it's sure to become a new icon of the salon in the years ahead.

*As of July 2011

ROLLER BALL







Roll Out the Style—Designs and Colours That Make Salon Work Fun

High-Performance Carbon Element Expands the Possibilities of Hair Design

In place of a conventional ceramic element, ROLLER BALL F employs a new, highly efficient carbon element that uses high-purity carbon (99.8% purity). What really impresses about this element is its outstanding speed and power. Formed into a circular shape that was very difficult to manufacture until now, it is the beauty industry's first* carbon element to be used in a far-infrared hair processor.

*As of July 2011

Advantage 1

Quickly Processes Colour and Perms That Last

Takara Belmont's carbon element reaches the selected output setting faster than the ceramic elements of conventional models. And, since the energy of the wavelength regions acting on the hair and chemicals is significantly higher, it thoroughly processes the colour*1 and the chemical reaction of perms*2. As a result, it improves the efficiency of work in the salon.

*1 Colour: acidic hair dyes *2 Perms: hot double-process perms

■ Comparison of Wavelength Regions

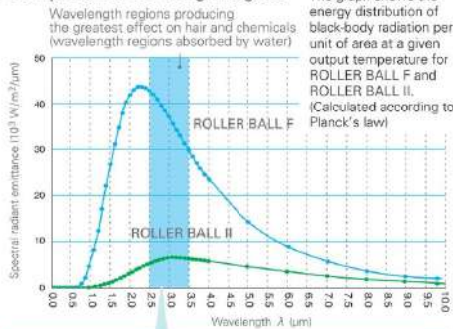

As a large amount of energy is produced in the most effective wavelength regions, the chemical process is further accelerated.

■ Comparison of Curling Strength (comparison using a curling agent)



Despite the shorter exposure time of ROLLER BALL F, the chemical agents are absorbed quickly, and the curl takes full effect, all the way to the tips.

■ Comparison of Curling Strength (comparison using a curling agent)

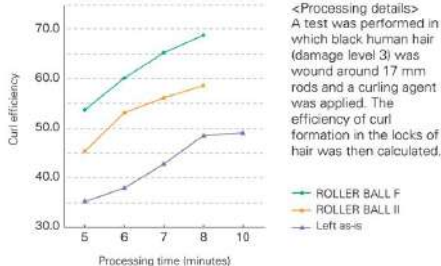

■ Comparison of Start-up Output

(test of the time required for the surface of the hair on a wig to reach 40°C)



Only around two minutes to reach target temperature—approximately half the time required by a conventional ceramic element!

■ Degree of Penetration into Hair and Persistence (comparison using an acidic dye)



With ROLLER BALL F, the dye was absorbed and took hold evenly. Even after the hair was shampooed seven times, there was relatively little loss of colour.

■ Degree of Penetration into Hair and Persistence (comparison using an acidic dye)

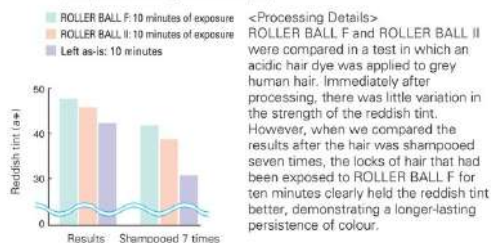

Designed for Better Work Performance and Ease of Use. Easy for Anyone to Master.

Slim and Lightweight—A Feather-Light Feeling

While a conventional machine (body plus stand) weighs 22 kg, this sleek new machine weighs just 15.6 kg. It's a full 30% lighter and much easier to move for salon staff. Takara Belmont also made the machine easier to access from behind and simplified the control panel.



Smoothly Slides Up and Down Using a Gas Cylinder System

Takara Belmont employed a gas cylinder for the height-adjustment feature. By simply stepping on the foot pedal, you can smoothly raise or lower the machine to your desired level without any jolting.



New Easy-View Control Panel

Takara Belmont rearranged the control panel and improved its visibility, so you can check the machine's operating status from a distance. It's also easy to select one of the four treatment modes—perm, colour, treatment, and manual—or one of the three sections—front, side, and nape—by simply pushing the corresponding button. In addition, a pilot lamp at the back of the main body lights up blue (when in operation) or blinks on and off (when an operation finishes, and so on) to indicate the machine's operating status.



New User-friendly Casters

Covered caster shaft reduces hair gets caught in the caster and this decreases maintenance frequency.



Glowing Light Indicates Changes in Temperature

When you switch the machine on, the element glows red; when the given output level is reached, it stops glowing. If the output level falls, the ring starts glowing again as it increases the output.

• Note: The brightness of the room can make it hard to see.



Easy-to-use stand with smooth rotatable casters.

Newly developed caster rotates more smoothly, allowing free 360° movement of Roller Ball F.



| Smoky color model |



Smoky Color Model – the soft colors match to any salon design

"Plants Green" is designed in the image of vitality of plants.
"Misty Blue" well matches with cool designed salon.
"Latte Brown" makes a good combination with woody warm atmosphere.
Unique yet soft, 3 popular smoky color are added in Roller Ball F series.

Stand Type



AK-S23S1-PG Plants Green



AK-S23S1-SB Misty Blue



AK-S23S1-LB Latte Brown

| 90th model |



The 90th Model is available in chic and muted colours; ebony and mahogany.

With its high quality furniture style such as the silver metallic painted ring and silver control panel, the 90th Model matches well with the decors of high-end salons and adds a touch of luxury to the salon spaces.

Stand Type



AK-S23S-E Ebony



AK-S23S-M Mahogany

Arm Type



AK-S23A-E Ebony



AK-S23A-M Mahogany

| Standard model |

Stand Type



AK-S23S1-B Black



AK-S23S1-W White

Arm Type



AK-S23A-B Black



AK-S23A-W White

| Creative model |

Stand Type



AK-S23S1-SL Silver



AK-S23S1-R Red

Arm Type



AK-S23A-SL Silver



AK-S23A-R Red

Arm Type

With the space-saving design for compact storage, the Arm Type can be used for two styling stations.

Use image

Arm Type Components

Arm



White / AY-DRASNW



Gray / AY-DRASNG



Silver / AY-DRASNSL

+

Head



Option

Cooling Fan for Cooling Down the Nape Area

Model number:

(Stand Type) AK-S23SF□□

(Arm Type) AK-S23AF□□

* Enter the colour code in the "□" space of the model number.

The two-minute cooling time is preprogrammed after the colour, perm, and treatment mode. The cooling fan is also available in the middle of operations to enhance the client's comfort.

* The cooling fan is a factory-installed option and unable to be mounted after shipment.

Please ask for the model with a cooling fan when placing an order.



The cooling fan for the Stand Type is silver-painted.



For the Arm type of the Creative Model and White, the colour of the cooling fan is same as the cover colour. For the 90th Model and Black, the colour is gray. (The photo shows the gray cooling fan.)

Stand Type

Dimensions (mm)

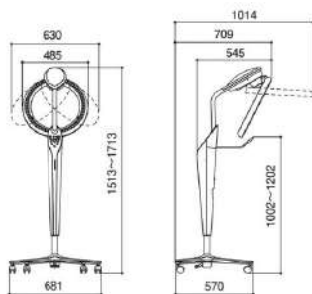

Specifications (mm)

- Rated voltage: 110V, 120V, 220V, 230V, 240V
- Rated current: 8.2A (110V), 9.0A (120V), 3.4A (220V), 3.5A (230V), 3.7A (240V)
- Size (WxDxH): head: 485 mm, foot: 681 mm x 1014 mm x 1513 mm [stroke: 200 mm] ● Weight: 15.6 kg
- Environmental temperature range: 10°C~40°C
- Environmental humidity range: 30%~75% RH ● Cord length: 3 m
- Safety devices: tilt sensor, rotating clutch function, power supply fuse
- Style: stand type

Dimensions (inch)

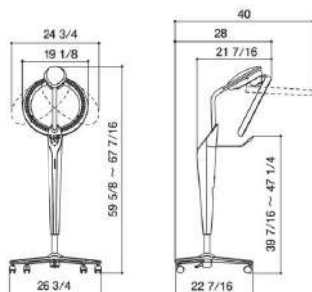

Specifications (inch)

- Rated voltage: 110V, 120V, 220V, 230V, 240V
- Rated current: 8.2A (110V), 9.0A (120V), 3.4A (220V), 3.5A (230V), 3.7A (240V)
- Size (WxDxH): head: 19-inch, foot: 26 3/4-inch x 40-inch x 59 5/8-inch [stroke: 7 3/4-inch] ● Weight: 34.5 lbs
- Environmental temperature range: 50°F ~ 104°F
- Environmental humidity range: 30%~75% RH ● Cord length: 10 ft
- Safety devices: tilt sensor, rotating clutch function, power supply fuse
- Style: stand type

Arm Type

Dimensions (mm)

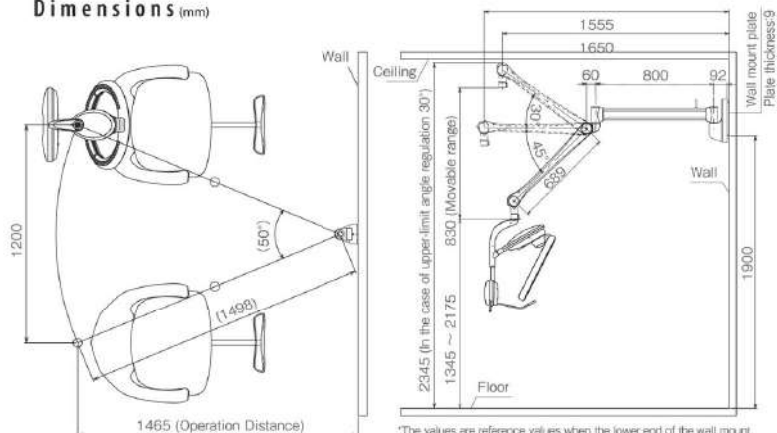

Specifications (mm)

- Rated voltage: 110V, 120V, 220V, 230V, 240V
- Rated current: 8.2A (110V), 9.0A (120V), 3.4A (220V), 3.5A (230V), 3.7A (240V)
- Weight: 18.0 kg
- Environmental temperature range: 10°C~40°C
- Environmental humidity range: 30%~75%RH
- Safety devices: tilt sensor, rotating clutch function, power supply fuse
- Style: arm type

*The values are reference values when the lower end of the wall mount plate is installed at a height of 1900mm from the floor surface.

Dimensions (inch)

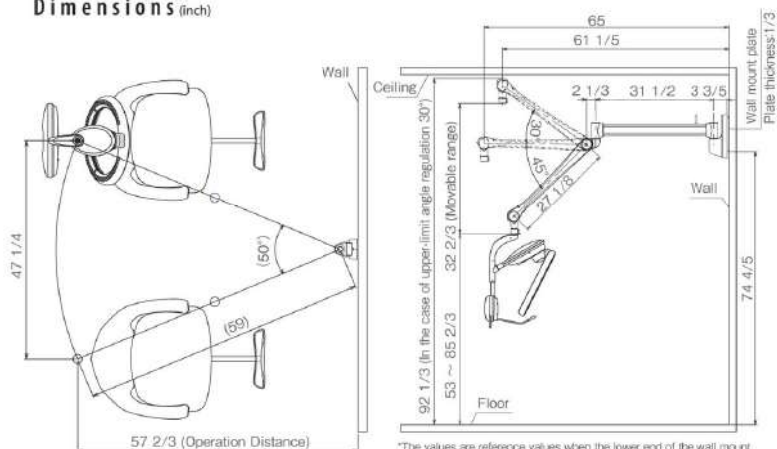

Specifications (inch)

- Rated voltage: 110V, 120V, 220V, 230V, 240V
- Rated current: 8.2A (110V), 9.0A (120V), 3.4A (220V), 3.5A (230V), 3.7A (240V)
- Weight: 39.7 lbs
- Environmental temperature range: 50°F~104°F
- Environmental humidity range: 30%~75%RH
- Safety devices: tilt sensor, rotating clutch function, power supply fuse
- Style: arm type

*The values are reference values when the lower end of the wall mount plate is installed at a height of 74 4/5 inch from the floor surface.

•Please note that, due to ongoing improvements, measurements and specifications are subject to change without prior notice.
•Actual colour may differ somewhat due to variations in printing.

TAKARA BELMONT GROUP

JAPAN TAKARA BELMONT CORPORATION, OSAKA HEADQUARTERS

Tel: +81-6-6212-3523 E-mail: beauty@takara-net.com Web: beauty.takarabelmont.co.jp

U.S.A. TAKARA BELMONT USA, INC.

Tel: +1-732-469-5000 E-mail: webmaster@takarabelmont.com Web: www.takarabelmont.com

CANADA TAKARA COMPANY, CANADA, LTD.

Tel: +1-905-822-2755 Toll-free: +1-800-268-5351 Web: www.takarabelmont.ca

BRAZIL TAKARA BELMONT PARA AMERICA DO SUL INDUSTRIA E COMERCIO DE MOVEIS LTDA.

Tel: +55-11-3147-4040 E-mail: takbel@takarabelmont.com.br Web: www.takarabelmont.com.br

U.K. TAKARA BELMONT (UK) LTD.

Tel: +44-20-7515-0333 E-mail: hairdressing@takara.co.uk Web: www.takara.co.uk

GERMANY TAKARA BELMONT FRANKFURT OFFICE

Tel: +49-69-2972-8090 E-mail: info@takarabelmont.de Web: www.takara.co.uk

KOREA TAKARA BELMONT (KOREA) CORPORATION

Tel: +82-2-413-5977 E-mail: info@takarabelmont.co.kr Web: www.takarabelmont.co.kr

TAIWAN TAKARA BELMONT (TAIWAN) CORPORATION

Tel: +886-2-8789-0809 E-mail: takara.twn@msa.hinet.net

CHINA TAKARA BELMONT (SHANGHAI) CORPORATION

Tel: +86-21-6272-8166 E-mail: takara-china@takarabelmont.com.cn Web: www.takarabelmont.com.cn

SINGAPORE TAKARA BELMONT SINGAPORE PTE. LTD.

Tel: +65-6316-1110 E-mail: hairdressing@takarabelmont.sg Web: www.takarabelmont.sg

